

EMDtr

the new generation of high temperature flow measurement

*Calibration free for nonconductive flow channels,
Low temperature drift*

Flow measuring device for fluid metals

Measurement principle: time measurement of traveling
magnetic field

PC interface USB, 20 mA signal output



Application area

The electro-magnetic flow measuring device **EMDtr** is suitable for the following measurement tasks:

- ✓ Monitoring of fluid metal flows within closed pipes for nearly all metallic materials
- ✓ Monitoring and control of flow during continuous, chill and centrifugal casting
- ✓ Monitoring and control of fluid metal loops within nuclear facilities
- ✓ Monitoring and flow control in open channels together with level detection

Your advantages

- contact-free measurement principle
- short reaction time for measurement
- available for various pipe dimensions
- extensive self-diagnostic functions
- impassible against electro-magnetic disturbances
- menu-oriented setup
- nearly calibration free
- calibrated with GaInSn and original flow channel to compensate the impact of conductive walls

Measurement principle:

A magnetic field with the form of an impulse is induced via a sending coil L_S into the liquid metal flow. The created eddy current magnetic field by this impulse is transported with the metal flow. With the help of two receiving coils L_{E1} and L_{E2} which are set in a defined distance $2a$ towards each other in the direction of the flow, the temporal derivation of eddy current magnetic field is measured with voltage signals. The time behavior of these two voltage signals are used to calculate the flow speed at a certain point. Given a turbulent flow and the corresponding setting of distance between the receiving coils this method is calculating the average flow speed in the pipe.

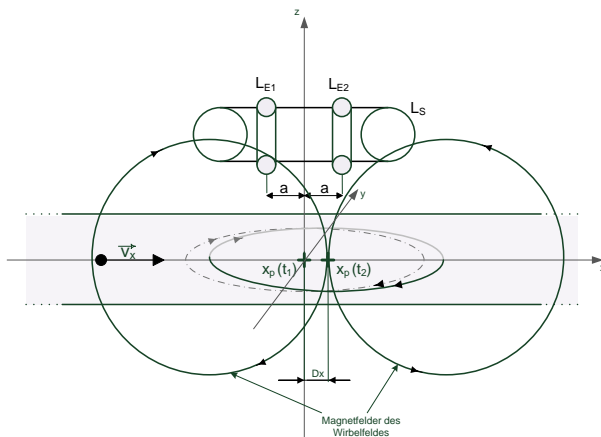

- $x_p(t_1)$... pole position at t_1
- $x_p(t_2)$... pole position at t_2
- a ... distance between $LE1/LE2$ to z -coordinate
- Δx ... traveled distance of eddy current magnetic field

Magnetic field lines of eddy currents

Block diagram of EMD tr:

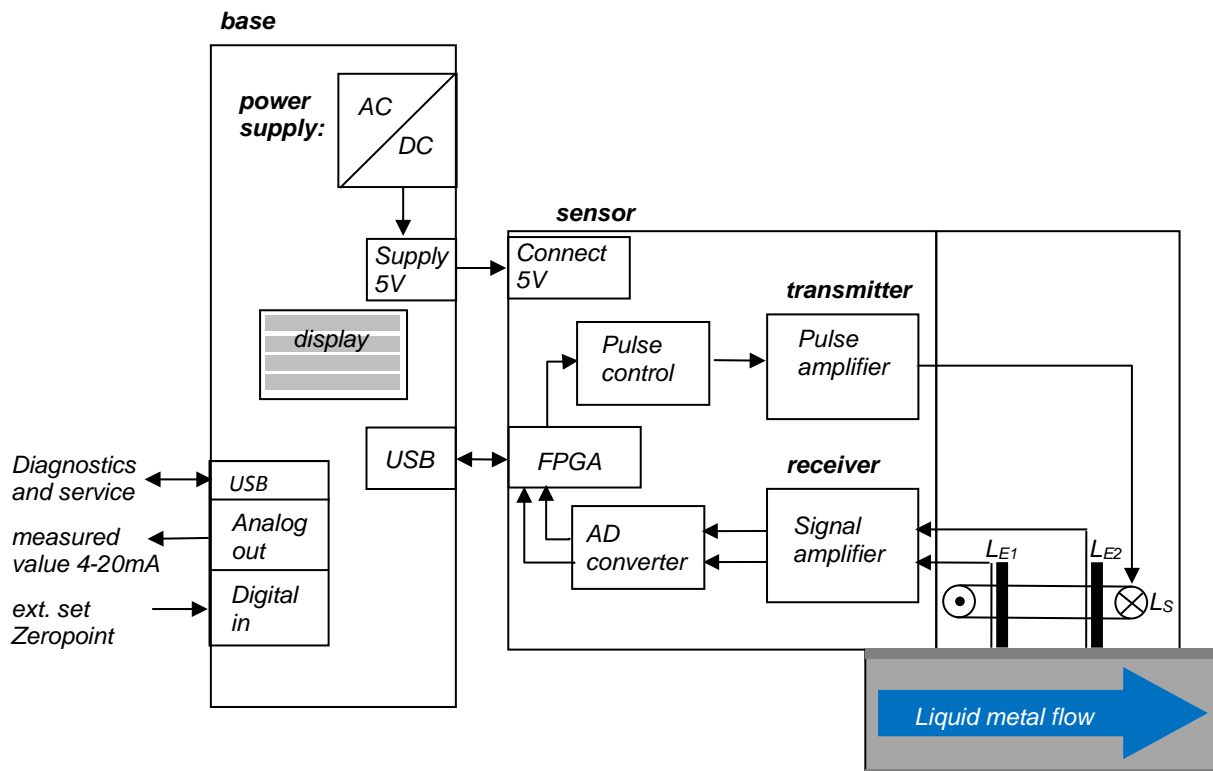

Technical data:

Power supply:

supply voltage:	230V AC
power input:	1 A, starting current 2 A

Dimensions / weight:

sensor unit WxDxH:	180 x 220 x (220+d_pipe) mm	5 kg
base unit WxDxH:	350 x 260 x 200 mm	8 kg
permitted wiring to the sensor unit:	5 m	
mounting position of sensor unit:	with the macor notch parallel to the pipe	
class of protection of base:	IP 54	
class of protection of sensor:	IP 50	

Previewed environmental conditions:

allowed ambient air temperature:	0°C to 30°C
allowed air humidity:	<85%
further installation conditions:	Dry interior room
operational temperature:	< 700°C medium temperature
medium:	Liquid metal with electrical conductivity $10^5 \text{ S/m} < \sigma \leq 10^7 \text{ S/m}$

Measurement ranges:

flow measurement range:	> 0.1m/s bubble-free flow
measured variables:	m/s, l/s, m ³ /h, kg/s (others on request)
dimensions of the flow channel (diameter):	standard: 10mm – 73 mm (larger dimensions on request)
measurement response time minimum	1s
input signal	24V(1s) external zeropoint-signal
output signal:	0-20mA / 4-20mA measured Value
interfaces:	USB
measurement error:	< 5% of full scale (FS) with cold calibration
reproducibility (short-term):	< 3% of FS
length of inlet path:	5x DN
length of outlet path:	3x DN

Operation:

display:	touchpanel
operation mode „measure“:	display of measurement values with unit
operation mode „diagramm“:	time course of measuring signals
operation mode “program”:	adjustment of channel specific parameters
operation mode “calibrate”:	two and zero-point calibration
operation mode “service”:	display of several parameters and update or restore the firmware

Imprint:

Representative:

SAAS
Systemanalyse und
Automatisierungsservice
GmbH

D - 01728 Bannewitz / Germany
Neues Leben 30

Tel. : +49 351 40468940

Fax: +49 351 40468941

E-mail: info@saas-online.de

Web: <http://www.saas-online.de/>

A co-operative development of the Helmholtz center Dresden-Rossendorf HZDR and SAAS GmbH supported by Sächsische Aufbaubank